

(12) INTERNATIONAL APPLICATION PUBLISHED UNDER THE PATENT COOPERATION TREATY (PCT)

(19) World Intellectual Property Organization  
International Bureau



(43) International Publication Date  
20 March 2003 (20.03.2003)

PCT

(10) International Publication Number  
WO 03/023179 A2

- (51) International Patent Classification: E21B [US/US]; 11007 Sprucedale Court, Houston, TX 77070 (US). RING, Lev [RU/US]; 14126 Heatherhill Place, Houston, TX 77077 (US). BRISCO, David, PAUL [US/US]; 405 Westridge Drive, Duncan, OK 73533 (US).
- (21) International Application Number: PCT/US02/25727
- (22) International Filing Date: 14 August 2002 (14.08.2002)
- (25) Filing Language: English
- (26) Publication Language: English
- (30) Priority Data:  
60/317,985 6 September 2001 (06.09.2001) US  
60/318,386 10 September 2001 (10.09.2001) US
- (71) Applicant (for all designated States except US): ENVEN-  
TURE GLOBAL TECHNOLOGY [US/US]; 16200 A.  
Park Row, Houston, TX 77084 (US).
- (72) Inventors; and
- (75) Inventors/Applicants (for US only): WADDELL, Kevin
- (81) Designated States (national): AE, AG, AL, AM, AT, AU, AZ, BA, BB, BG, BR, BY, BZ, CA, CH, CN, CO, CR, CU, CZ, DE, DK, DM, DZ, EC, EE, ES, FI, GB, GD, GE, GH, GM, HR, HU, ID, IL, IN, IS, JP, KE, KG, KP, KR, KZ, LC, LK, LR, LS, LT, LU, LV, MA, MD, MG, MK, MN, MW, MX, MZ, NO, NZ, PL, PT, RO, RU, SD, SE, SG, SI, SK, SL, TJ, TM, TR, TT, TZ, UA, UG, US, UZ, VN, YU, ZA, ZW.
- (84) Designated States (regional): ARIPO patent (GH, GM, KE, LS, MW, MZ, SD, SL, SZ, TZ, UG, ZM, ZW),

[Continued on next page]

(54) Title: SYSTEM FOR LINING A WELLBORE CASING

(57) Abstract: A system for lining a wellbore casing.



WO 03/023179 A2

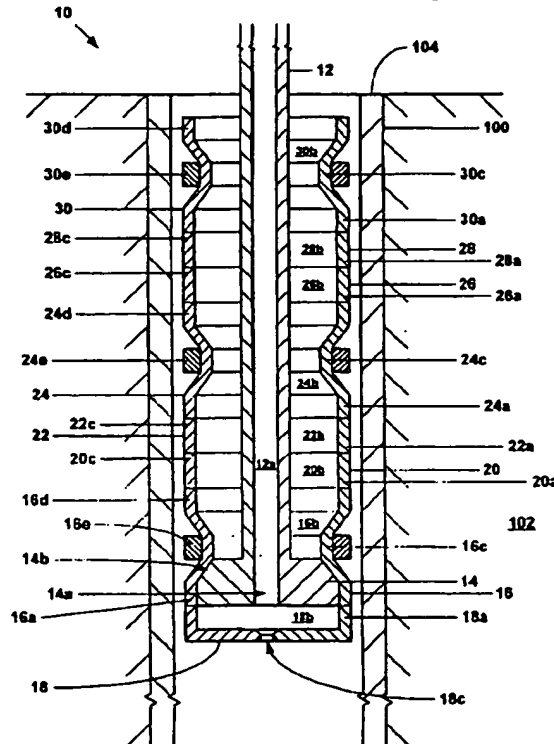

Eurasian patent (AM, AZ, BY, KG, KZ, MD, RU, TJ, TM),  
European patent (AT, BE, BG, CH, CY, CZ, DE, DK, EE,  
ES, FI, FR, GB, GR, IE, IT, LU, MC, NL, PT, SE, SK,  
TR), OAPI patent (BF, BJ, CF, CG, CI, CM, GA, GN, GQ,  
GW, ML, MR, NE, SN, TD, TG).

**Published:**

— without international search report and to be republished  
upon receipt of that report

**Declaration under Rule 4.17:**

— of inventorship (Rule 4.17(iv)) for US only

For two-letter codes and other abbreviations, refer to the "Guidance Notes on Codes and Abbreviations" appearing at the beginning of each regular issue of the PCT Gazette.

## SYSTEM FOR LINING A WELLBORE CASING

## Cross Reference To Related Applications

5 The present application claims the benefit of the filing dates of U.S. provisional patent application serial no. 60/317,985, attorney docket no. 25791.67, filed on 9/6/2001, and U.S. provisional patent application serial no. 60/318,386, attorney docket no. 25791.67.02, filed on 9/10/2001, the disclosures of which are incorporated herein by reference.

10 The present application is a continuation-in-part of PCT/US00/18635, attorney docket no. 25791.25.02, filed on July 9, 2000, which claimed the benefit of the filing dates of U.S. provisional patent application serial no. 60/146,203, attorney docket no. 25791.25, filed on July 29, 1999, and U.S. provisional patent application serial no. 60/143,039, attorney docket no. 25791.26, filed on July 9, 1999, the disclosures of which are incorporated herein by reference.

15 The present application is related to the following: (1) U.S. patent application serial no. 09/454,139, attorney docket no. 25791.03.02, filed on 12/3/1999, (2) U.S. patent application serial no. 09/510,913, attorney docket no. 25791.7.02, filed on 2/23/2000, (3) U.S. patent application serial no. 09/502,350, attorney docket n . 25791.8.02, filed on 2/10/2000, (4) U.S. patent application serial no. 09/440,338, attorney docket no. 25791.9.02, filed on 11/15/1999, (5) U.S. patent application serial no. 09/523,460, attorney docket no. 25791.11.02, filed on 3/10/2000, (6) U.S. patent application serial no. 09/512,895, attorney docket no. 25791.12.02, filed on 2/24/2000, (7) U.S. patent application serial no. 09/511,941, attorney docket no. 20 25791.16.02, filed on 2/24/2000, (8) U.S. patent application serial no. 09/588,946, attorney docket no. 25791.17.02, filed on 6/7/2000, (9) U.S. patent application serial no. 09/559,122, attorney docket no. 25791.23.02, filed on 4/26/2000, (10) PCT patent application serial no. PCT/US00/18635, attorney docket no. 25791.25.02, filed on 7/9/2000, (11) U.S. provisional patent application serial no. 60/162,671, attorney docket no. 25791.27, filed on 11/1/1999, (12) U.S. provisional patent application serial no. 60/154,047, attorney docket 25 no. 25791.29, filed on 9/16/1999, (13) U.S. provisional patent application serial no. 60/159,082, attorney docket no. 25791.34, filed on 10/12/1999, (14) U.S. provisional patent application serial no. 60/159,039, attorney docket no. 25791.36, filed on 10/12/1999, (15) U.S. provisional patent application serial no. 60/159,033, attorney docket no. 25791.37, filed on 10/12/1999, (16) U.S. provisional patent application serial no. 60/212,359, attorney docket no. 25791.38, filed on 6/19/2000, (17) U.S. provisional patent application serial no. 30 60/165,228, attorney docket no. 25791.39, filed on 11/12/1999, (18) U.S. provisional patent application serial no. 60/221,443, attorney docket no. 25791.45, filed on 7/28/2000, (19) U.S. provisional patent application serial no. 60/221,645, attorney docket no. 25791.46, filed on 7/28/2000, (20) U.S. provisional patent application serial no. 60/233,638, attorney docket no. 25791.47, filed on 9/18/2000, (21) U.S. provisional patent application serial no. 60/237,334, attorney docket no. 25791.48, filed on 10/2/2000, (22) U.S. provisional patent application serial 35 no. 60/270,007, attorney docket no. 25791.50, filed on 2/20/2001; (23) U.S. provisional patent application serial no. 60/262,434, attorney docket no. 25791.51, filed on 1/17/2001; (24) U.S. provisional patent application serial no. 60/259,486, attorney docket no. 25791.52, filed on 1/3/2001; (25) U.S. provisional patent application serial no. 60/303,740, attorney docket no. 25791.61, filed on 7/6/2001; (26) U.S. provisional patent application serial no. 60/313,453, attorney docket no. 25791.59, filed on 8/20/2001; (27) U.S. provisional patent application serial 40 no. 60/317,985, attorney docket no. 25791.67, filed on 9/6/2001, and (28) U.S. provisional patent application

serial no. 60/318,386, attorney docket no. 25791.67.02, filed on 9/10/2001, the disclosures of which are incorporated herein by reference.

#### Background

5 This invention relates generally to wellbore casings, and in particular to wellbore casings that are formed using expandable tubing.

Conventionally, when a wellbore is created, a number of casings are installed in the borehole to prevent collapse of the borehole wall and to prevent undesired outflow of drilling fluid into the formation or inflow of fluid from the formation into the borehole. The borehole is drilled in intervals whereby a casing which is to be installed in a lower borehole interval is lowered through a previously installed casing of an upper borehole interval. As a consequence of this procedure the casing of the lower interval is of smaller diameter than the casing of the upper interval. Thus, the casings are in a nested arrangement with casing diameters decreasing in downward direction. Cement annuli are provided between the outer surfaces of the casings and the borehole wall to seal the casings from the borehole wall. As a consequence of this nested arrangement a relatively large borehole diameter is required at the upper part of the wellbore. Such a large borehole diameter involves increased costs due to heavy casing handling equipment, large drill bits and increased volumes of drilling fluid and drill cuttings. Moreover, increased drilling rig time is involved due to required cement pumping, cement hardening, required equipment changes due to large variations in hole diameters drilled in the course of the well, and the large volume of cuttings drilled and removed.

20 The present invention is directed to overcoming one or more of the limitations of the existing procedures for forming wellbore casings.

#### Summary

According to one aspect of the present invention, a system for lining a wellbore casing is provided that includes a tubular support member defining a first passage, a tubular expansion cone defining a second passage fluidly coupled to the first passage coupled to an end of the tubular support member and comprising a tapered end, a tubular liner coupled to and supported by the tapered end of the tubular expansion cone, and a shoe defining a valveable passage coupled to an end of the tubular liner, wherein the tubular liner includes one or more expandable tubular members that each include a tubular body comprising an intermediate portion and first and second expanded end portions coupled to opposing ends of the intermediate portion, and a sealing member coupled to the exterior surface of the intermediate portion, and one or more other tubular members coupled to the expandable tubular members, wherein the inside diameters of the other tubular members are greater than or equal to the outside diameter of the tubular expansion cone.

According to another aspect of the present invention, a method of lining a wellbore casing is provided that includes positioning a tubular liner within the wellbore casing, and radially expanding one or more discrete portions of the tubular liner into engagement with the wellbore casing.

35 According to another aspect of the present invention, a system for lining a wellbore casing is provided that includes means for positioning a tubular liner within the wellbore casing, and means for radially expanding one or more discrete portions of the tubular liner into engagement with the wellbore casing. In an exemplary embodiment, a plurality of discrete portions of the tubular liner are radially expanded into engagement with the wellbore casing.

According to another aspect of the present invention, an apparatus is provided that includes a subterranean formation defining a borehole, a casing positioned in and coupled to the borehole, and a tubular liner positioned in and coupled to the casing at one or more discrete locations.

#### Brief Description of the Drawings

5 Fig. 1a is a cross sectional illustration of the placement of an illustrative embodiment of a system for lining a wellbore casing within a borehole having a preexisting wellbore casing.

Fig. 1b is a cross sectional illustration of the system of Fig. 1a during the injection of a fluidic material into the tubular support member.

10 Fig. 1c is a cross sectional illustration of the system of Fig. 1b during the pressurization of the interior portion of the shoe after sealing off the valveable fluid passage of the shoe.

Fig. 1d is a cross sectional illustration of the system of Fig. 1c during the continued injection of the fluidic material into the tubular support member.

Fig. 1e is a cross sectional illustration of the system of Fig. 1d after the completion of the radial expansion and plastic deformation of the expandable tubular members.

15 Fig. 1f is a cross sectional illustration of the system of Fig. 1e after machining the bottom central portion of the shoe.

Fig. 2 is a cross sectional illustration of an illustrative embodiment of the expandable tubular members of the system of Fig. 1a.

20 Fig. 3 is a flow chart illustration of an illustrative embodiment of a method for manufacturing the expandable tubular member of Fig. 2.

Fig. 4a is a cross sectional illustration of an illustrative embodiment of the upsetting of the ends of a tubular member.

Fig. 4b is a cross sectional illustration of the expandable tubular member of Fig. 4a after radially expanding and plastically deforming the ends of the expandable tubular member.

25 Fig. 4c is a cross sectional illustration of the expandable tubular member of Fig. 4b after forming threaded connections on the ends of the expandable tubular member.

Fig. 4d is a cross sectional illustration of the expandable tubular member of Fig. 4c after coupling sealing members to the exterior surface of the intermediate unexpanded portion of the expandable tubular member.

30 Fig. 5 is a cross-sectional illustration of an exemplary embodiment of a tubular expansion cone.

Fig. 6 is a cross-sectional illustration of an exemplary embodiment of a tubular expansion cone.

#### Description of the Illustrative Embodiments

Referring initially to Fig. 1a, the reference numeral 10 refers, in general, to a system for lining a wellbore casing that includes a tubular support member 12 that defines a passage 12a. A tubular expansion cone 14 that defines a passage 14a is coupled to an end of the tubular support member 12. In an exemplary embodiment, the tubular expansion cone 14 includes a tapered outer surface 14b for reasons to be described.

A pre-expanded end 16a of a first expandable tubular member 16 that defines a passage 16b is adapted to mate with and be supported by the tapered outer surface 14b of the tubular expansion cone 14. The first expandable tubular member 16 further includes an unexpanded intermediate portion 16c, another pre-expanded end 16d, and a sealing member 16e coupled to the exterior surface of the unexpanded intermediate portion. In

an exemplary embodiment, the inside and outside diameters of the pre-expanded ends, 16a and 16d, of the first expandable tubular member 16 are greater than the inside and outside diameters of the unexpanded intermediate portion 16c. An end 18a of a shoe 18 that defines a passage 18b and a valveable passage 18c is coupled to the pre-expanded end 16a of the first expandable tubular member 16 by a conventional threaded connection.

5 An end 20a of a tubular member 20 that defines a passage 20b is coupled to the other pre-expanded end 16d of the first expandable tubular member 16 by a conventional threaded connection. Another end 20c of the tubular member 20 is coupled to an end 22a of a tubular member 22 that defines a passage 22b by a conventional threaded connection. A pre-expanded end 24a of a second expandable tubular member 24 that defines a passage 24b is coupled to the other end 22c of the tubular member 22. The second expandable tubular member 24 further includes an unexpanded intermediate portion 24c, another pre-expanded end 24d, and a sealing member 24e coupled to the exterior surface of the unexpanded intermediate portion. In an exemplary embodiment, the inside and outside diameters of the pre-expanded ends, 24a and 24d, of the second expandable tubular member 24 are greater than the inside and outside diameters of the unexpanded intermediate portion 24c.

10 An end 26a of a tubular member 26 that defines a passage 26b is coupled to the other pre-expanded end 24d of the second expandable tubular member 24 by a conventional threaded connection. Another end 26c of the tubular member 26 is coupled to an end 28a of a tubular member 28 that defines a passage 28b by a conventional threaded connection. A pre-expanded end 30a of a third expandable tubular member 30 that defines a passage 30b is coupled to the other end 28c of the tubular member 28. The third expandable tubular member 30 further includes an unexpanded intermediate portion 30c, another pre-expanded end 30d, and a sealing member 30e coupled to the exterior surface of the unexpanded intermediate portion. In an exemplary embodiment, the inside and outside diameters of the pre-expanded ends, 30a and 30d, of the third expandable tubular member 30 are greater than the inside and outside diameters of the unexpanded intermediate portion 30c.

15 In an exemplary embodiment, the inside and outside diameters of the pre-expanded ends, 16a, 16d, 24a, 24d, 30a and 30d, of the expandable tubular members, 16, 24, and 30, and the tubular members 20, 22, 26, and 28, are substantially equal. In several exemplary embodiments, the sealing members, 16e, 24e, and 30e, of the expandable tubular members, 16, 24, and 30, respectively, further include anchoring elements for engaging the wellbore casing 104. In several exemplary embodiments, the tubular members, 20, 22, 26, and 28, are conventional tubular members having threaded end connections suitable for use in an oil or gas well, an underground pipeline, or as a structural support.

20 In an exemplary embodiment, as illustrated in Fig. 1a, the system 10 is initially positioned in a borehole 100 formed in a subterranean formation 102 that includes a pre-existing wellbore casing 104. The borehole 100 may be positioned in any orientation from vertical to horizontal. Furthermore, the wellbore casing 104 may be, for example, a wellbore casing for an oil or gas well, an underground pipeline, or a structural support. In an exemplary embodiment, the upper end of the tubular support member 12 may be supported in a conventional manner using, for example, a slip joint, or equivalent device in order to permit upward movement of the tubular support member and tubular expansion cone 14 relative to one or more of the expandable tubular members, 16, 24, and 30, and tubular members, 20, 22, 26, and 28.

25 In an exemplary embodiment, as illustrated in Fig. 1b, a fluidic material 106 is then injected into the system 10, through the passages, 12a and 14a, of the tubular support member 12 and tubular expansion cone 14,

respectively. The fluidic material 106 then passes into the passages, 18b and 18c, of the shoe 18 into the borehole 100.

In an exemplary embodiment, as illustrated in Fig. 1c, a ball 108, plug or other equivalent device is then introduced into the injected fluidic material 106. The ball 108 will then pass through the passages, 12a, 14a, and 18b, of the tubular support member 12, the tubular expansion cone 14, and the shoe 18, respectively, and will then be positioned within the valveable passage 18c of the shoe. In this manner, the valveable passage 18c of the shoe 18 is closed thereby permitting the passage 18b of the shoe below the tubular expansion cone 14 to be pressurized by the continued injection of the fluidic material 106.

In an exemplary embodiment, as illustrated in Fig. 1d, the continued injection of the fluidic material 106 through the passages, 12a and 14a, of the tubular support member 12 and the tubular expansion cone 14, respectively, pressurizes the passage 18b of the shoe 18 below the tubular expansion cone thereby radially expanding and plastically deforming the expandable tubular member 16 off of the tapered external surface 14b of the tubular expansion cone 14. In particular, the intermediate non pre-expanded portion 16c of the expandable tubular member 16 is radially expanded and plastically deformed off of the tapered external surface 14b of the tubular expansion cone 14. As a result, the sealing member 16e engages the interior surface of the wellbore casing 104. Consequently, the radially expanded intermediate portion 16c of the expandable tubular member 16 is thereby coupled to the wellbore casing 104. In an exemplary embodiment, the radially expanded intermediate portion 16c of the expandable tubular member 16 is also thereby anchored to the wellbore casing 104.

The continued injection of the fluidic material 106 through the passages, 12a and 14a, of the tubular support member 12 and the tubular expansion cone 14, respectively, will then displace the tubular expansion cone 14 upwardly into engagement with the pre-expanded end 24a of the second expandable tubular member 24.

In an exemplary embodiment, as illustrated in Fig. 1e, the continued injection of the fluidic material 106 through the passages, 12a and 14a, of the tubular support member 12 and tubular expansion cone 14, respectively, will then pressurize the passages 18b, 16b, 20b and 22b below the tubular expansion cone thereby radially expanding and plastically deforming the second expandable tubular member 24 off of the tapered external surface 14b of the tubular expansion cone 14. In particular, the intermediate non pre-expanded portion 24c of the second expandable tubular member 24 is radially expanded and plastically deformed off of the tapered external surface 14b of the tubular expansion cone 14. As a result, the sealing member 24e engages the interior surface of the wellbore casing 104. Consequently, the radially expanded intermediate portion 24c of the second expandable tubular member 24 is thereby coupled to the wellbore casing 104. In an exemplary embodiment, the radially expanded intermediate portion 24c of the second expandable tubular member 24 is also thereby anchored to the wellbore casing 104.

The continued injection of the fluidic material 106 through the passages, 12a and 14a, of the tubular support member 12 and the tubular expansion cone 14, respectively, will then displace the tubular expansion cone 14 upwardly into engagement with the pre-expanded end 30a of the third expandable tubular member 30.

The continued injection of the fluidic material 106 through the passages, 12a and 14a, of the tubular support member 12 and tubular expansion cone 14, respectively, will then pressurize the passages 18b, 16b, 20b, 22b, 24b, 26b, and 28b below the tubular expansion cone thereby radially expanding and plastically deforming the third expandable tubular member 30 off of the tapered external surface 14b of the tubular expansion cone 14.

In particular, the intermediate non pre-expanded portion 30c of the third expandable tubular member 30 is radially expanded and plastically deformed off of the tapered external surface 14b of the tubular expansion cone 14. As a result, the sealing member 30e engages the interior surface of the wellbore casing 104. Consequently, the radially expanded intermediate portion 30c of the third expandable tubular member 30 is thereby coupled to the wellbore casing 104. In an exemplary embodiment, the radially expanded intermediate portion 30c of the third expandable tubular member 30 is also thereby anchored to the wellbore casing 104.

In an exemplary embodiment, during the injection of the fluidic material 106 through the passages, 12a and 14a, of the tubular support member 12 and the tubular expansion cone 14, respectively, the tubular support member 12 and tubular expansion cone 14 are displaced upwardly relative to the expandable tubular members, 16, 24, and 30, and the tubular members, 20, 22, 26, and 28, by applying an upward axial force to the upper end of the tubular support member.

After completing the radial expansion and plastic deformation of the third expandable tubular member 30, the tubular support member 12 and the tubular expansion cone 14 are removed from the wellbore 100.

In an exemplary embodiment, as illustrated in Fig. 1f, the lower central portion of the shoe 18 is then removed using a conventional milling device.

Thus, during the operation of the system 10, the intermediate non pre-expanded portions, 16c, 24c, and 30c, of the expandable tubular members, 16, 24, and 30, respectively, are radially expanded and plastically deformed by the pressurization of the interior passages, 18a, 16b, 20b, 22b, 24b, 26b, 28b, and 30b, of the shoe 18, the expandable tubular member 16, the tubular members, 20 and 22, the expandable tubular member 24, the tubular members, 26 and 28, and the expandable tubular member 30, respectively, below the tubular expansion cone 14. As a result, the sealing members, 16e, 24e, and 30e, are displaced in the radial direction into engagement with the wellbore casing 104 thereby coupling the shoe 18, the expandable tubular member 16, the tubular members, 20 and 22, the expandable tubular member 24, the tubular members, 26 and 28, and the expandable tubular member 30 to the wellbore casing. Furthermore, as a result, the expandable connections between the expandable tubular members, 16, 24, and 30, the shoe 18, and the tubular members, 20, 22, 26, and 28, do not have to be expandable connections thereby providing significant cost savings.

Furthermore, in the system 10, the tubular members 20, 22, 26, and 28 are interleaved among the expandable tubular members, 16, 24, and 30. As a result, because only the intermediate non pre-expanded portions, 16c, 24c, and 30c, of the expandable tubular members, 16, 24, and 30, respectively, are radially expanded and plastically deformed, the tubular members, 20, 22, 26, and 28 can be conventional tubular members thereby significantly reducing the cost and complexity of the system 10. Moreover, because only the intermediate non pre-expanded portions, 16c, 24c, and 30c, of the expandable tubular members, 16, 24, and 30, respectively, are radially expanded and plastically deformed, the number and length of the interleaved tubular members, 20, 22, 26, and 28 can be much greater than the number and length of the expandable tubular members. In an exemplary embodiment, the total length of the intermediate non pre-expanded portions, 16c, 24c, and 30c, of the expandable tubular members, 16, 24, and 30, is approximately 200 feet, and the total length of the tubular members, 20, 22, 26, and 28, is approximately 3800 feet. Consequently, in an exemplary embodiment, a liner having a total length of approximately 4000 feet is coupled to a wellbore casing by radially expanding and plastically deforming a total length of only approximately 200 feet.



Furthermore, the sealing members 16e, 24e, and 30e, of the expandable tubular members, 16, 24, and 30, respectively, are used to couple the expandable tubular members and the tubular members, 20, 22, 26, and 28 to the wellbore casing 104, the radial gap between the tubular members, the expandable tubular members, and the wellbore casing 104 may be large enough to effectively eliminate the possibility of damage to the expandable tubular members and tubular members during the placement of the system 10 within the wellbore casing.

In an exemplary embodiment, after the sealing member 16e of the expandable tubular member 16 has been radially expanded into engagement with the wellbore casing 104, the expandable tubular members, 24 and 30, are radially expanded and plastically deformed by injecting the fluidic material 106 and applying an upward axial force to the tubular support member 12 and tubular expansion cone 14. In this manner, radial expansion and plastic deformation of the expandable tubular members, 24 and 30, may be enhanced.

In an exemplary embodiment, after the sealing member 16e of the expandable tubular member 16 has been radially expanded into engagement with the wellbore casing 104, the expandable tubular members, 24 and 30, are radially expanded and plastically deformed by only applying an upward axial force to the tubular support member 12 and tubular expansion cone 14. In this manner, radial expansion and plastic deformation of the expandable tubular members, 24 and 30, may be provided without the further continued injection of the fluidic material 106.

In an exemplary embodiment, the pre-expanded ends, 16a, 16d, 24a, 24d, 30a, and 30d, of the expandable tubular members, 16, 24, and 30, respectively, and the tubular members, 20, 22, 26, and 28, have outside diameters and wall thicknesses of 8.375 inches and 0.350 inches, respectively; prior to the radial expansion, the intermediate non pre-expanded portions, 16c, 24c, and 30c, of the expandable tubular members, 16, 24, and 30, respectively, have outside diameters of 7.625 inches; the tubular members, 20, 22, 26, and 28, have inside diameters of 7.675 inches; after the radial expansion, the inside diameters of the intermediate portions, 16c, 24c, and 30c, of the expandable tubular members, 16, 24, and 30, are equal to 7.675 inches; and the wellbore casing 104 has an inside diameter of 8.755 inches.

In an exemplary embodiment, the pre-expanded ends, 16a, 16d, 24a, 24d, 30a, and 30d, of the expandable tubular members, 16, 24, and 30, respectively, and the tubular members, 20, 22, 26, and 28, have outside diameters and wall thicknesses of 4.500 inches and 0.250 inches, respectively; prior to the radial expansion, the intermediate non pre-expanded portions, 16c, 24c, and 30c, of the expandable tubular members, 16, 24, and 30, respectively, have outside diameters of 4.000 inches; the tubular members, 20, 22, 26, and 28, have inside diameters of 4.000 inches; after the radial expansion, the inside diameters of the intermediate portions, 16c, 24c, and 30c, of the expandable tubular members, 16, 24, and 30, are equal to 4.000 inches; and the wellbore casing 104 has an inside diameter of 4.892 inches.

In an exemplary embodiment, the system 10 is used to form or repair a wellbore casing, a pipeline, or a structural support.

Referring now to Fig. 2, an exemplary embodiment of an expandable tubular member 200 will now be described. The tubular member 200 defines an interior region 200a and includes a first end 200b including a first threaded connection 200ba, a first tapered portion 200c, an intermediate portion 200d, a second tapered portion 200e, and a second end 200f including a second threaded connection 200fa. The tubular member 200 further preferably includes an intermediate sealing member 200g that is coupled to the exterior surface of the

intermediate portion 200d.

In an exemplary embodiment, the tubular member 200 has a substantially annular cross section. The tubular member 200 may be fabricated from any number of conventional commercially available materials such as, for example, Oilfield Country Tubular Goods (OCTG), 13 chromium steel tubing/casing, or L83, J55, or  
5 P110 API casing.

In an exemplary embodiment, the interior 200a of the tubular member 200 has a substantially circular cross section. Furthermore, in an exemplary embodiment, the interior region 200a of the tubular member includes a first inside diameter  $D_1$ , an intermediate inside diameter  $D_{INT}$ , and a second inside diameter  $D_2$ . In an exemplary embodiment, the first and second inside diameters,  $D_1$  and  $D_2$ , are substantially equal. In an  
10 exemplary embodiment, the first and second inside diameters,  $D_1$  and  $D_2$ , are greater than the intermediate inside diameter  $D_{INT}$ .

The first end 200b of the tubular member 200 is coupled to the intermediate portion 200d by the first tapered portion 200c, and the second end 200f of the tubular member is coupled to the intermediate portion by the second tapered portion 200e. In an exemplary embodiment, the outside diameters of the first and second  
15 ends, 200b and 200f, of the tubular member 200 is greater than the outside diameter of the intermediate portion 200d of the tubular member. The first and second ends, 200b and 200f, of the tubular member 200 include wall thicknesses,  $t_1$  and  $t_2$ , respectively. In an exemplary embodiment, the outside diameter of the intermediate portion 200d of the tubular member 200 ranges from about 75% to 98% of the outside diameters of the first and second ends, 200a and 200f. The intermediate portion 200d of the tubular member 200 includes a wall  
20 thickness  $t_{INT}$ .

In an exemplary embodiment, the wall thicknesses  $t_1$  and  $t_2$  are substantially equal in order to provide substantially equal burst strength for the first and second ends, 200a and 200f, of the tubular member 200. In an exemplary embodiment, the wall thicknesses,  $t_1$  and  $t_2$ , are both greater than the wall thickness  $t_{INT}$  in order to optimally match the burst strength of the first and second ends, 200a and 200f, of the tubular member 200 with  
25 the intermediate portion 200d of the tubular member 200.

In an exemplary embodiment, the first and second tapered portions, 200c and 200e, are inclined at an angle,  $\alpha$ , relative to the longitudinal direction ranging from about 0 to 30 degrees in order to optimally facilitate the radial expansion of the tubular member 200. In an exemplary embodiment, the first and second tapered portions, 200c and 200e, provide a smooth transition between the first and second ends, 200a and 200f, and the  
30 intermediate portion 200d, of the tubular member 200 in order to minimize stress concentrations.

The intermediate sealing member 200g is coupled to the outer surface of the intermediate portion 200d of the tubular member 200. In an exemplary embodiment, the intermediate sealing member 200g seals the interface between the intermediate portion 200d of the tubular member 200 and the interior surface of a wellbore casing 205 after the radial expansion and plastic deformation of the intermediate portion 200d of the tubular  
35 member 200. In an exemplary embodiment, the intermediate sealing member 200g has a substantially annular cross section. In an exemplary embodiment, the outside diameter of the intermediate sealing member 200g is selected to be less than the outside diameters of the first and second ends, 200a and 200f, of the tubular member 200 in order to optimally protect the intermediate sealing member 200g during placement of the tubular member 200 within the wellbore casings 205. The intermediate sealing member 200g may be fabricated from any  
40 number of conventional commercially available materials such as, for example, thermoset or thermoplastic

polymers. In an exemplary embodiment, the intermediate sealing member 200g is fabricated from thermoset polymers in order to optimally seal the radially expanded intermediate portion 200d of the tubular member 200 with the wellbore casing 205. In several alternative embodiments, the sealing member 200g includes one or more rigid anchors for engaging the wellbore casing 205 to thereby anchor the radially expanded and plastically deformed intermediate portion 200d of the tubular member 200 to the wellbore casing.

Referring to Figs. 3, and 4a to 4d, in an exemplary embodiment, the tubular member 200 is formed by a process 300 that includes the steps of: (1) upsetting both ends of a tubular member in step 305; (2) expanding both upset ends of the tubular member in step 310; (3) stress relieving both expanded upset ends of the tubular member in step 315; (4) forming threaded connections in both expanded upset ends of the tubular member in step 320; and (5) putting a sealing material on the outside diameter of the non-expanded intermediate portion of the tubular member in step 325.

As illustrated in FIG. 4a, in step 305, both ends, 400a and 400b, of a tubular member 400 are upset using conventional upsetting methods. The upset ends, 400a and 400b, of the tubular member 400 include the wall thicknesses  $t_1$  and  $t_2$ . The intermediate portion 400c of the tubular member 400 includes the wall thickness  $t_{INT}$  and the interior diameter  $D_{INT}$ . In an exemplary embodiment, the wall thicknesses  $t_1$  and  $t_2$  are substantially equal in order to provide burst strength that is substantially equal along the entire length of the tubular member 400. In an exemplary embodiment, the wall thicknesses  $t_1$  and  $t_2$  are both greater than the wall thickness  $t_{INT}$  in order to provide burst strength that is substantially equal along the entire length of the tubular member 400, and also to optimally facilitate the formation of threaded connections in the first and second ends, 400a and 400b.

As illustrated in Fig. 4b, in steps 310 and 315, both ends, 400a and 400b, of the tubular member 400 are radially expanded using conventional radial expansion methods, and then both ends, 400a and 400b, of the tubular member are stress relieved. The radially expanded ends, 400a and 400b, of the tubular member 400 include the interior diameters  $D_1$  and  $D_2$ . In an exemplary embodiment, the interior diameters  $D_1$  and  $D_2$  are substantially equal in order to provide a burst strength that is substantially equal. In an exemplary embodiment, the ratio of the interior diameters  $D_1$  and  $D_2$  to the interior diameter  $D_{INT}$  ranges from about 100% to 120% in order to facilitate the subsequent radial expansion of the tubular member 400.

In a preferred embodiment, the relationship between the wall thicknesses  $t_1$ ,  $t_2$ , and  $t_{INT}$  of the tubular member 400; the inside diameters  $D_1$ ,  $D_2$  and  $D_{INT}$  of the tubular member 400; the inside diameter  $D_{wellbore}$  of the wellbore casing that the tubular member 400 will be inserted into; and the outside diameter  $D_{cone}$  of the expansion cone that will be used to radially expand the tubular member 400 within the wellbore casing is given by the following expression:

$$D_{wellbore} - 2 * t_1 \geq D_1 \geq \frac{1}{t_1} \left[ (t_1 - t_{INT}) * D_{cone} + t_{INT} * D_{INT} \right] \quad (1)$$

where  $t_1 = t_2$ ; and

$$D_1 = D_2.$$

By satisfying the relationship given in equation (1), the expansion forces placed upon the tubular member 400 during the subsequent radial expansion process are substantially equalized. More generally, the relationship given in equation (1) may be used to calculate the optimal geometry for the tubular member 400 for subsequent radial expansion and plastic deformation of the tubular member 400 for fabricating and/or repairing a wellbore casing, a pipeline, or a structural support.

As illustrated in FIG. 4c, in step 320, conventional threaded connections, 400d and 400e, are formed in both expanded ends, 400a and 400b, of the tubular member 400. In an exemplary embodiment, the threaded connections, 400d and 400e, are provided using conventional processes for forming pin and box type threaded connections available from Atlas-Bradford.

5 In an exemplary embodiment, in step 325, a sealing member 400f is then applied onto the outside diameter of the non-expanded intermediate portion 400c of the tubular member 400. The sealing member 400f may be applied to the outside diameter of the non-expanded intermediate portion 400c of the tubular member 400 using any number of conventional commercially available methods. In a preferred embodiment, the sealing member 400f is applied to the outside diameter of the intermediate portion 400c of the tubular member 400 using  
10 commercially available chemical and temperature resistant adhesive bonding.

In an exemplary embodiment, the expandable tubular members, 16, 24, and 30, of the system 10 are substantially identical to, and/or incorporate one or more of the teachings of, the tubular members 200 and 400.

Referring to Fig. 5, an exemplary embodiment of tubular expansion cone 500 for radially expanding the tubular members 16, 24, 30, 200 and 400 will now be described. The expansion cone 500 defines a passage  
15 500a and includes a front end 505, a rear end 510, and a radial expansion section 515.

In an exemplary embodiment, the radial expansion section 515 includes a first conical outer surface 520 and a second conical outer surface 525. The first conical outer surface 520 includes an angle of attack  $\alpha_1$  and the second conical outer surface 525 includes an angle of attack  $\alpha_2$ . In an exemplary embodiment, the angle of attack  $\alpha_1$  is greater than the angle of attack  $\alpha_2$ . In this manner, the first conical outer surface 520 radially  
20 overexpands the intermediate portions, 16c, 24c, 30c, 200d, and 400c, of the tubular members, 16, 24, 30, 200, and 400, and the second conical outer surface 525 radially overexpands the pre-expanded first and second ends, 16a and 16d, 24a and 24d, 30a and 30d, 200b and 200f, and 400a and 400b, of the tubular members, 16, 24, 30, 200 and 400. In an exemplary embodiment, the first conical outer surface 520 includes an angle of attack  $\alpha_1$  ranging from about 8 to 20 degrees, and the second conical outer surface 525 includes an angle of attack  $\alpha_2$   
25 ranging from about 4 to 15 degrees in order to optimally radially expand and plastically deform the tubular members, 16, 24, 30, 200 and 400. More generally, the expansion cone 500 may include 3 or more adjacent conical outer surfaces having angles of attack that decrease from the front end 505 of the expansion cone 500 to the rear end 510 of the expansion cone 500.

Referring to Fig. 6, another exemplary embodiment of a tubular expansion cone 600 defines a passage  
30 600a and includes a front end 605, a rear end 610, and a radial expansion section 615. In an exemplary embodiment, the radial expansion section 615 includes an outer surface having a substantially parabolic outer profile thereby providing a paraboloid shape. In this manner, the outer surface of the radial expansion section 615 provides an angle of attack that constantly decreases from a maximum at the front end 605 of the expansion cone 600 to a minimum at the rear end 610 of the expansion cone. The parabolic outer profile of the outer  
35 surface of the radial expansion section 615 may be formed using a plurality of adjacent discrete conical sections and/or using a continuous curved surface. In this manner, the region of the outer surface of the radial expansion section 615 adjacent to the front end 605 of the expansion cone 600 may optimally radially overexpand the intermediate portions, 16c, 24c, 30c, 200d, and 400c, of the tubular members, 16, 24, 30, 200, and 400, while the region of the outer surface of the radial expansion section 615 adjacent to the rear end 610 of the expansion  
40 cone 600 may optimally radially overexpand the pre-expanded first and second ends, 16a and 16d, 24a and 24d,

30a and 30d, 200b and 200f, and 400a and 400b, of the tubular members, 16, 24, 30, 200 and 400. In an exemplary embodiment, the parabolic profile of the outer surface of the radial expansion section 615 is selected to provide an angle of attack that ranges from about 8 to 20 degrees in the vicinity of the front end 605 of the expansion cone 6800 and an angle of attack in the vicinity of the rear end 610 of the expansion cone 600 from about 4 to 15 degrees.

In an exemplary embodiment, the tubular expansion cone 14 of the system 10 is substantially identical to the expansion cones 500 or 600, and/or incorporates one or more of the teachings of the expansion cones 500 and/or 600.

A system for lining a wellbore casing has been described that includes a tubular support member defining a first passage, a tubular expansion cone defining a second passage fluidically coupled to the first passage coupled to an end of the tubular support member and comprising a tapered end, a tubular liner coupled to and supported by the tapered end of the tubular expansion cone, and a shoe defining a valveable passage coupled to an end of the tubular liner, wherein the tubular liner includes one or more expandable tubular members that each include a tubular body comprising an intermediate portion and first and second expanded end portions coupled to opposing ends of the intermediate portion, and a sealing member coupled to the exterior surface of the intermediate portion, and one or more other tubular members coupled to the expandable tubular members, wherein the inside diameters of the other tubular members are greater than or equal to the outside diameter of the tubular expansion cone. In an exemplary embodiment, the wall thicknesses of the first and second expanded end portions are greater than the wall thickness of the intermediate portion. In an exemplary embodiment, each expandable tubular member further includes a first tubular transitional member coupled between the first expanded end portion and the intermediate portion, and a second tubular transitional member coupled between the second expanded end portion and the intermediate portion, wherein the angles of inclination of the first and second tubular transitional members relative to the intermediate portion ranges from about 0 to 30 degrees. In an exemplary embodiment, the outside diameter of the intermediate portion ranges from about 75 percent to about 98 percent of the outside diameters of the first and second expanded end portions. In an exemplary embodiment, the burst strength of the first and second expanded end portions is substantially equal to the burst strength of the intermediate tubular section. In an exemplary embodiment, the ratio of the inside diameters of the first and second expanded end portions to the interior diameter of the intermediate portion ranges from about 100 to 120 percent. In an exemplary embodiment, the relationship between the wall thicknesses  $t_1$ ,  $t_2$ , and  $t_{INT}$  of the first expanded end portion, the second expanded end portion, and the intermediate portion, respectively, of the expandable tubular members, the inside diameters  $D_1$ ,  $D_2$  and  $D_{INT}$  of the first expanded end portion, the second expanded end portion, and the intermediate portion, respectively, of the expandable tubular members, and the inside diameter  $D_{wellbore}$  of the wellbore casing that the expandable tubular member will be inserted into, and the outside diameter  $D_{cone}$  of the expansion cone that will be used to radially expand the expandable tubular member within the wellbore casing is given by the following expression:

$$D_{wellbore} - 2t_1 \geq D_1 \geq \frac{1}{t_1} \left\{ (t_1 - t_{INT}) * D_{cone} + t_{INT} * D_{INT} \right\}$$

wherein  $t_1 = t_2$ ; and wherein  $D_1 = D_2$ . In an exemplary embodiment, the tapered end of the tubular expansion cone includes a plurality of adjacent discrete tapered sections. In an exemplary embodiment, the angle of attack

of the adjacent discrete tapered sections increases in a continuous manner from one end of the tubular expansion cone to the opposite end of the tubular expansion cone. In an exemplary embodiment, the tapered end of the tubular expansion cone includes a paraboloid body. In an exemplary embodiment, the angle of attack of the outer surface of the paraboloid body increases in a continuous manner from one end of the paraboloid body to the opposite end of the paraboloid body. In an exemplary embodiment, the tubular liner includes a plurality of expandable tubular members, and the other tubular members are interleaved among the expandable tubular members.

A method of lining a wellbore casing has also been described that includes positioning a tubular liner within the wellbore casing, and radially expanding one or more discrete portions of the tubular liner into engagement with the wellbore casing. In an exemplary embodiment, a plurality of discrete portions of the tubular liner are radially expanded into engagement with the wellbore casing. In an exemplary embodiment, the remaining portions of the tubular liner are not radially expanded. In an exemplary embodiment, the discrete portions of the tubular liner are radially expanded by injecting a fluidic material into the tubular liner. In an exemplary embodiment, the tubular liner includes a plurality of tubular members; and wherein one or more of the tubular members are radially expanded into engagement with the wellbore casing and one or more of the tubular members are not radially expanded into engagement with the wellbore casing. In an exemplary embodiment, the tubular members that are radially expanded into engagement with the wellbore casing include a portion that is radially expanded into engagement with the wellbore casing and a portion that is not radially expanded into engagement with the wellbore casing. In an exemplary embodiment, the tubular liner includes one or more expandable tubular members that each include a tubular body comprising an intermediate portion and first and second expanded end portions coupled to opposing ends of the intermediate portion, and a sealing member coupled to the exterior surface of the intermediate portion, and one or more other tubular members coupled to the expandable tubular members, wherein the inside diameters of the other tubular members are greater than or equal to the maximum inside diameters of the expandable tubular members. In an exemplary embodiment, the tubular liner includes a plurality of expandable tubular members, and the other tubular members are interleaved among the expandable tubular members.

A system for lining a wellbore casing has also been described that includes means for positioning a tubular liner within the wellbore casing, and means for radially expanding one or more discrete portions of the tubular liner into engagement with the wellbore casing. In an exemplary embodiment, a plurality of discrete portions of the tubular liner are radially expanded into engagement with the wellbore casing. In an exemplary embodiment, the remaining portions of the tubular liner are not radially expanded. In an exemplary embodiment, the discrete portions of the tubular liner are radially expanded by injecting a fluidic material into the tubular liner. In an exemplary embodiment, the tubular liner includes a plurality of tubular members; and wherein one or more of the tubular members are radially expanded into engagement with the wellbore casing and one or more of the tubular members are not radially expanded into engagement with the wellbore casing. In an exemplary embodiment, the tubular members that are radially expanded into engagement with the wellbore casing comprise a portion that is radially expanded into engagement with the wellbore casing and a portion that is not radially expanded into engagement with the wellbore casing.

An apparatus has also been described that includes a subterranean formation defining a borehole, a casing positioned in and coupled to the borehole, and a tubular liner positioned in and coupled to the casing at

one or more discrete locations. In an exemplary embodiment, the tubular liner is coupled to the casing at a plurality of discrete locations. In an exemplary embodiment, the tubular liner is coupled to the casing by a process that includes positioning the tubular liner within the casing, and radially expanding one or more discrete portions of the tubular liner into engagement with the casing. In an exemplary embodiment, a plurality of discrete portions of the tubular liner are radially expanded into engagement with the casing. In an exemplary embodiment, the remaining portions of the tubular liner are not radially expanded. In an exemplary embodiment, the discrete portions of the tubular liner are radially expanded by injecting a fluidic material into the tubular liner. In an exemplary embodiment, the tubular liner includes a plurality of tubular members; and wherein one or more of the tubular members are radially expanded into engagement with the casing and one or more of the tubular members are not radially expanded into engagement with the casing. In an exemplary embodiment, the tubular members that are radially expanded into engagement with the casing comprise a portion that is radially expanded into engagement with the casing and a portion that is not radially expanded into engagement with the casing. In an exemplary embodiment, the tubular liner includes one or more expandable tubular members that each include a tubular body comprising an intermediate portion and first and second expanded end portions coupled to opposing ends of the intermediate portion, and a sealing member coupled to the exterior surface of the intermediate portion, and one or more other tubular members coupled to the expandable tubular members, wherein the inside diameters of the other tubular members are greater than or equal to the maximum inside diameters of the expandable tubular members. In an exemplary embodiment, the tubular liner includes a plurality of expandable tubular members, and the other tubular members are interleaved among the expandable tubular members.

It is understood that variations may be made in the foregoing without departing from the scope of the invention. For example, the system 10 may be used to form or repair a wellbore casing, an underground pipeline, a structural support, or a tubing. Furthermore, the system 10 may include one or more expandable tubular members and one or more other tubular members. In addition, the system 10 may include a plurality of expandable tubular members, and the other tubular members may be interleaved among the expandable tubular members.

Although illustrative embodiments of the invention have been shown and described, a wide range of modification, changes and substitution is contemplated in the foregoing disclosure. In some instances, some features of the present invention may be employed without a corresponding use of the other features. Accordingly, it is appropriate that the appended claims be construed broadly and in a manner consistent with the scope of the invention.

## Claims

1. A system for lining a wellbore casing, comprising:  
a tubular support member defining a first passage;  
5 a tubular expansion cone defining a second passage fluidically coupled to the first passage coupled to an end of the tubular support member and comprising a tapered end;  
a tubular liner coupled to and supported by the tapered end of the tubular expansion cone; and  
a shoe defining a valveable passage coupled to an end of the tubular liner;  
wherein the tubular liner comprises:  
10 one or more expandable tubular members that each comprise:  
a tubular body comprising an intermediate portion and first and second expanded end portions coupled to opposing ends of the intermediate portion; and  
a sealing member coupled to the exterior surface of the intermediate portion; and  
one or more other tubular members coupled to the expandable tubular members;  
15 wherein the inside diameters of the other tubular members are greater than or equal to the outside diameter of the tubular expansion cone.
2. The system of claim 1, wherein the wall thicknesses of the first and second expanded end portions are greater than the wall thickness of the intermediate portion.
- 20 3. The system of claim 1, wherein each expandable tubular member further comprises:  
a first tubular transitional member coupled between the first expanded end portion and the intermediate portion; and  
a second tubular transitional member coupled between the second expanded end portion and the  
25 intermediate portion;  
wherein the angles of inclination of the first and second tubular transitional members relative to the intermediate portion ranges from about 0 to 30 degrees.
4. The system of claim 1, wherein the outside diameter of the intermediate portion ranges from about 75  
30 percent to about 98 percent of the outside diameters of the first and second expanded end portions.
5. The system of claim 1, wherein the burst strength of the first and second expanded end portions is substantially equal to the burst strength of the intermediate tubular section.
- 35 6. The system of claim 1, wherein the ratio of the inside diameters of the first and second expanded end portions to the interior diameter of the intermediate portion ranges from about 100 to 120 percent.
7. The system of claim 1, wherein the relationship between the wall thicknesses  $t_1$ ,  $t_2$ , and  $t_{INT}$  of the first  
40 expanded end portion, the second expanded end portion, and the intermediate portion, respectively, of the expandable tubular members, the inside diameters  $D_1$ ,  $D_2$  and  $D_{INT}$  of the first expanded end portion, the second



expanded end portion, and the intermediate portion, respectively, of the expandable tubular members, and the inside diameter  $D_{\text{wellbore}}$  of the wellbore casing that the expandable tubular member will be inserted into, and the outside diameter  $D_{\text{cone}}$  of the expansion cone that will be used to radially expand the expandable tubular member within the wellbore casing is given by the following expression:

$$5 \quad D_{\text{wellbore}} - 2t_1 \geq D_1 \geq \frac{1}{t_1} \left\{ (t_1 - t_{\text{DRT}})^2 D_{\text{cone}} + t_{\text{DRT}}^2 D_{\text{DRT}} \right\}$$

wherein  $t_1 = t_2$ ; and wherein  $D_1 = D_2$ .

8. The system of claim 1, wherein the tapered end of the tubular expansion cone comprises:  
a plurality of adjacent discrete tapered sections.

10

9. The system of claim 8, wherein the angle of attack of the adjacent discrete tapered sections increases in a continuous manner from one end of the tubular expansion cone to the opposite end of the tubular expansion cone.

15

10. The system of claim 1, wherein the tapered end of the tubular expansion cone comprises:  
an paraboloid body.

11. The system of claim 10, wherein the angle of attack of the outer surface of the paraboloid body increases in a continuous manner from one end of the paraboloid body to the opposite end of the paraboloid  
20 body.

12. The system of claim 1, wherein the tubular liner comprises a plurality of expandable tubular members; and wherein the other tubular members are interleaved among the expandable tubular members.

25

13. A method of lining a wellbore casing, comprising:  
positioning a tubular liner within the wellbore casing; and  
radially expanding one or more discrete portions of the tubular liner into engagement with the wellbore  
casing.

30

14. The method of claim 13, wherein a plurality of discrete portions of the tubular liner are radially expanded into engagement with the wellbore casing.

15. The method of claim 13, wherein the remaining portions of the tubular liner are not radially expanded.

35

16. The method of claim 13, wherein the discrete portions of the tubular liner are radially expanded by injecting a fluidic material into the tubular liner.

40

17. The method of claim 13, wherein the tubular liner comprises a plurality of tubular members; and wherein one or more of the tubular members are radially expanded into engagement with the wellbore casing and one or more of the tubular members are not radially expanded into engagement with the wellbore casing.

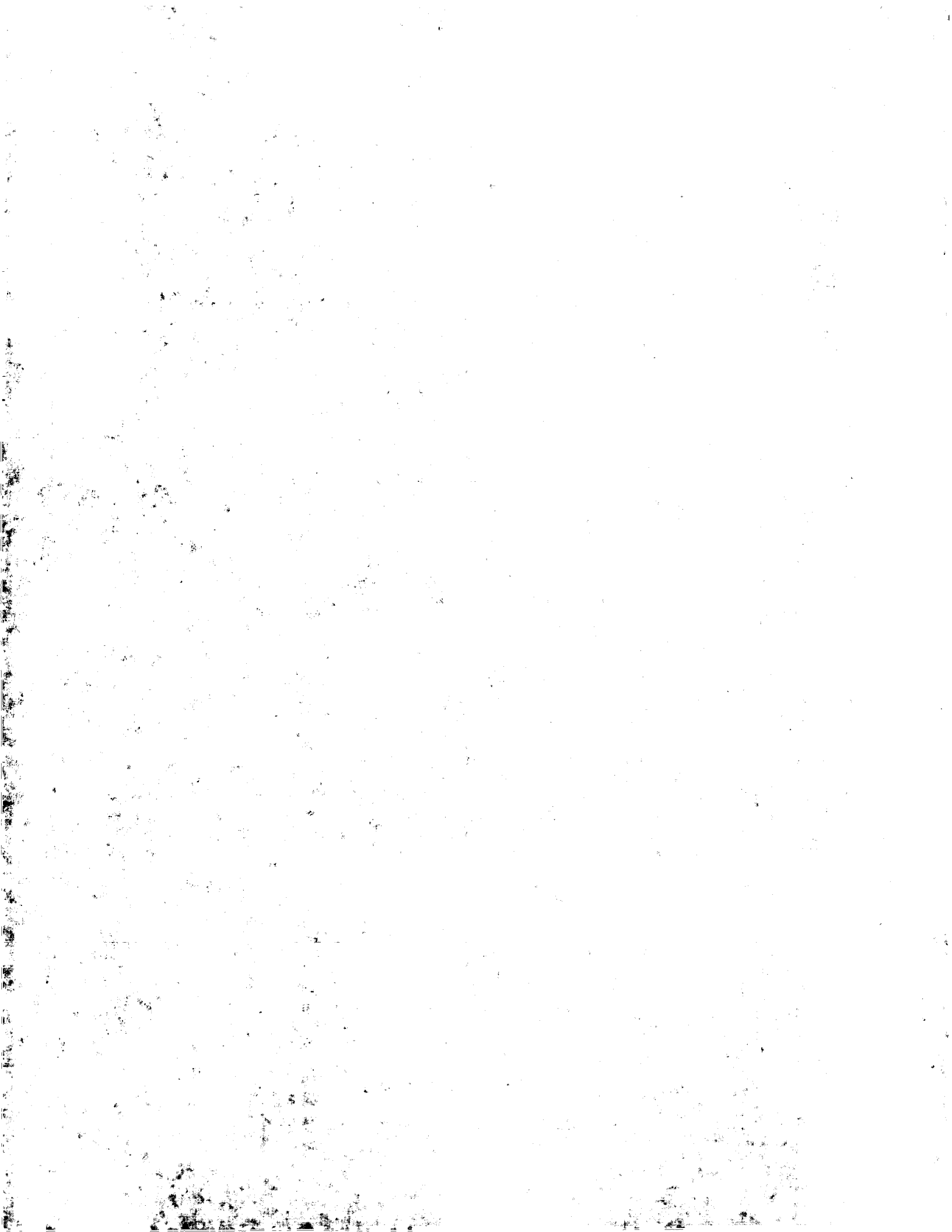

18. The method of claim 17, wherein the tubular members that are radially expanded into engagement with the wellbore casing comprise a portion that is radially expanded into engagement with the wellbore casing and a portion that is not radially expanded into engagement with the wellbore casing.
- 5
19. The method of claim 13, wherein the tubular liner comprises:  
one or more expandable tubular members that each comprise:  
a tubular body comprising an intermediate portion and first and second expanded end portions coupled to opposing ends of the intermediate portion; and  
10 a sealing member coupled to the exterior surface of the intermediate portion; and  
a sealing member coupled to the exterior surface of the intermediate portion; and  
one or more other tubular members coupled to the expandable tubular members;  
wherein the inside diameters of the other tubular members are greater than or equal to the maximum  
inside diameters of the expandable tubular members.
- 15
20. The method of claim 19, wherein the tubular liner comprises a plurality of expandable tubular members; and wherein the other tubular members are interleaved among the expandable tubular members.
21. A system for lining a wellbore casing, comprising:  
means for positioning a tubular liner within the wellbore casing; and  
20 means for radially expanding one or more discrete portions of the tubular liner into engagement with the wellbore casing.
22. The system of claim 21, wherein a plurality of discrete portions of the tubular liner are radially expanded into engagement with the wellbore casing.
- 25
23. The system of claim 21, wherein the remaining portions of the tubular liner are not radially expanded.
24. The system of claim 21, wherein the discrete portions of the tubular liner are radially expanded by injecting a fluidic material into the tubular liner.
- 30
25. The system of claim 21, wherein the tubular liner comprises a plurality of tubular members; and wherein one or more of the tubular members are radially expanded into engagement with the wellbore casing and one or more of the tubular members are not radially expanded into engagement with the wellbore casing.
- 35
26. The system of claim 25, wherein the tubular members that are radially expanded into engagement with the wellbore casing comprise a portion that is radially expanded into engagement with the wellbore casing and a portion that is not radially expanded into engagement with the wellbore casing.
- 40
27. An apparatus, comprising:  
a subterranean formation defining a borehole;

a casing positioned in and coupled to the borehole; and  
a tubular liner positioned in and coupled to the casing at one or more discrete locations.

- 5 28. The apparatus of claim 27, wherein the tubular liner is coupled to the casing at a plurality of discrete locations.
29. The apparatus of claim 27, wherein the tubular liner is coupled to the casing by a process that comprises:  
10 positioning the tubular liner within the casing; and  
radially expanding one or more discrete portions of the tubular liner into engagement with the casing.
30. The system of claim 29, wherein a plurality of discrete portions of the tubular liner are radially expanded into engagement with the casing.
- 15 31. The system of claim 29, wherein the remaining portions of the tubular liner are not radially expanded.
32. The system of claim 29, wherein the discrete portions of the tubular liner are radially expanded by injecting a fluidic material into the tubular liner.
- 20 33. The system of claim 29, wherein the tubular liner comprises a plurality of tubular members; and wherein one or more of the tubular members are radially expanded into engagement with the casing and one or more of the tubular members are not radially expanded into engagement with the casing.
- 25 34. The system of claim 29, wherein the tubular members that are radially expanded into engagement with the casing comprise a portion that is radially expanded into engagement with the casing and a portion that is not radially expanded into engagement with the casing.
35. The system of claim 29, wherein prior to the radial expansion the tubular liner comprises:  
30 one or more expandable tubular members that each comprise:  
a tubular body comprising an intermediate portion and first and second expanded end portions coupled to opposing ends of the intermediate portion; and  
a sealing member coupled to the exterior surface of the intermediate portion; and  
one or more other tubular members coupled to the expandable tubular members;  
wherein the inside diameters of the other tubular members are greater than or equal to the maximum  
35 inside diameters of the expandable tubular members.
36. The system of claim 35, wherein the tubular liner comprises a plurality of expandable tubular members; and wherein the other tubular members are interleaved among the expandable tubular members.

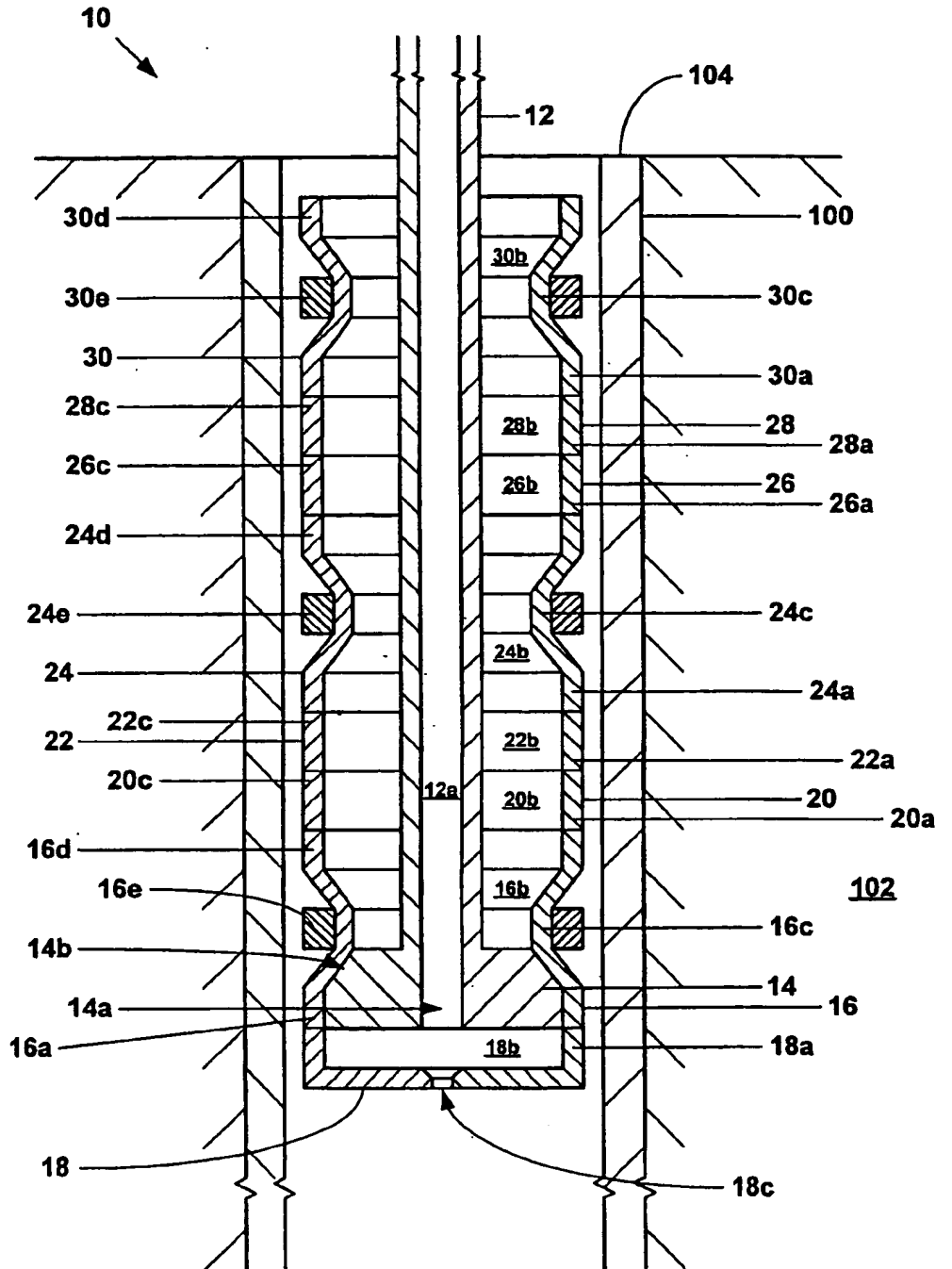

Fig. 1a

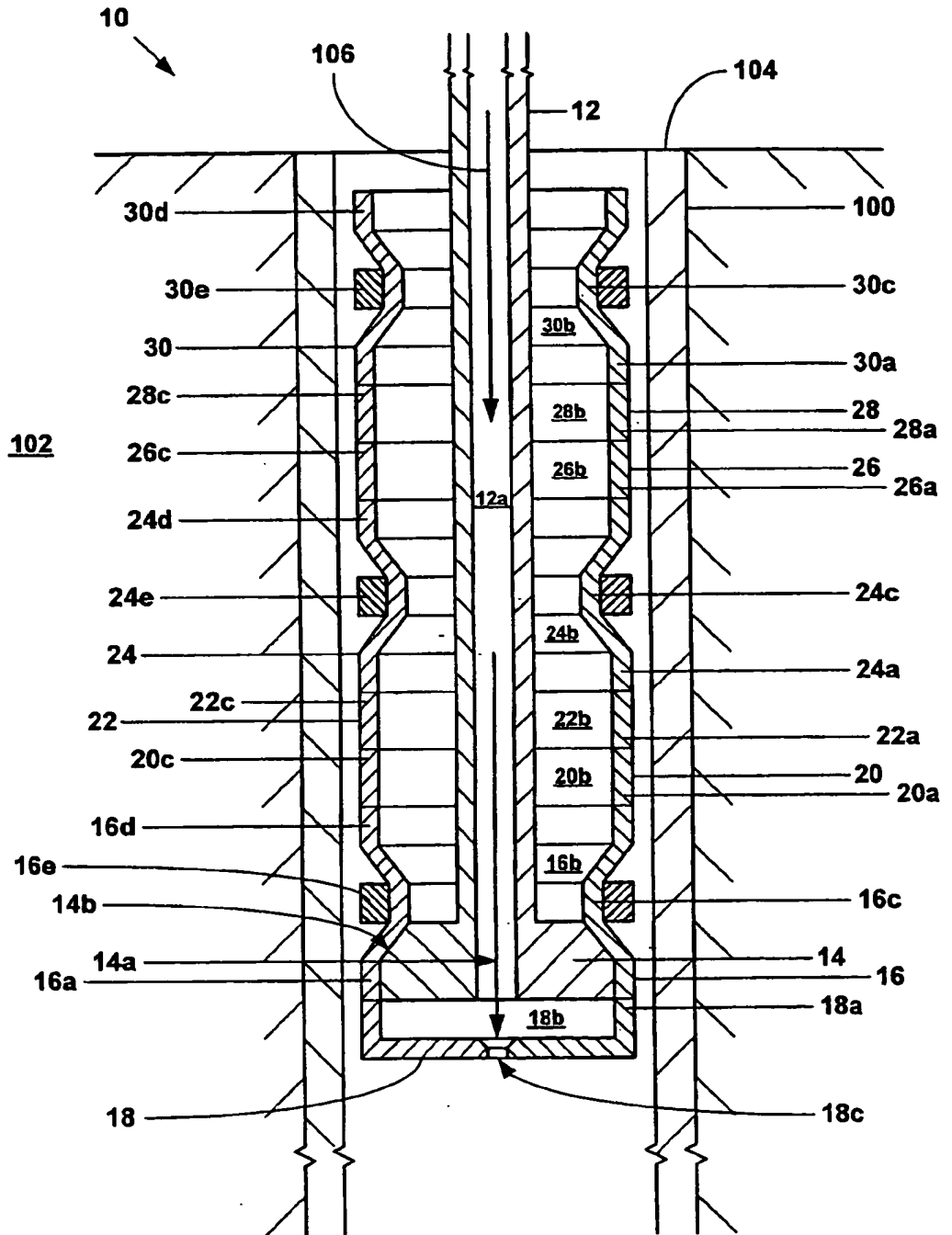

Fig. 1b

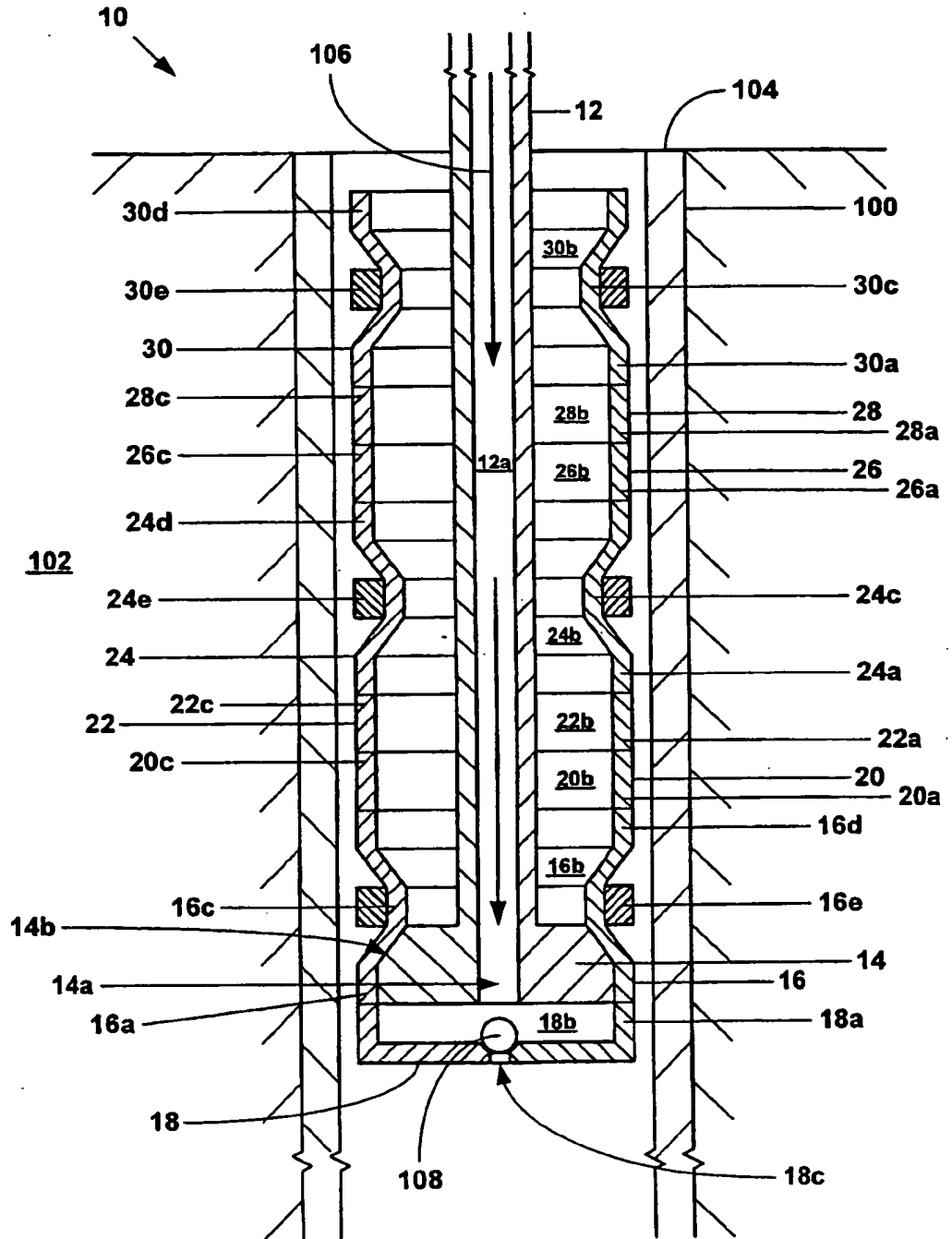

Fig. 1c

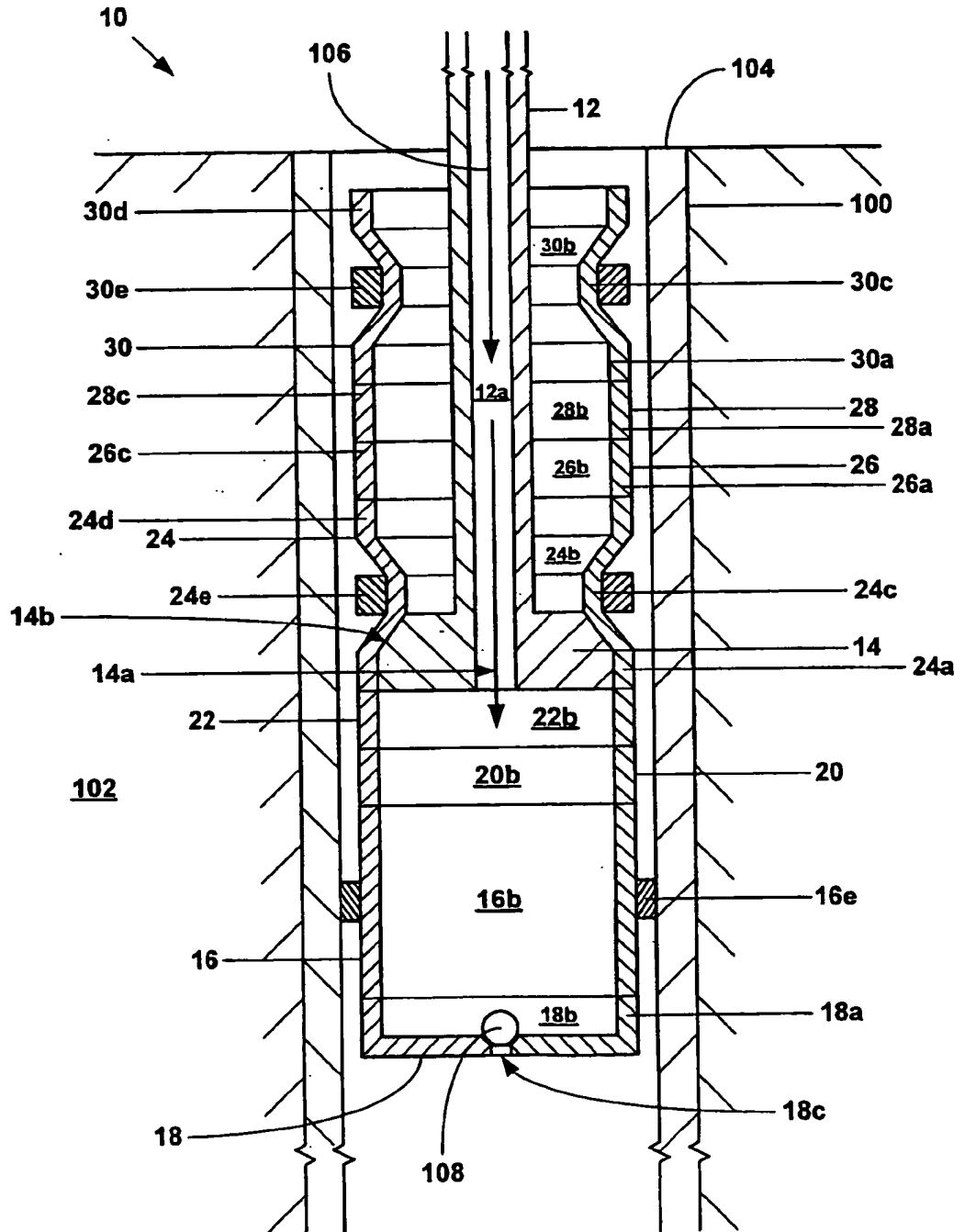

Fig. 1d



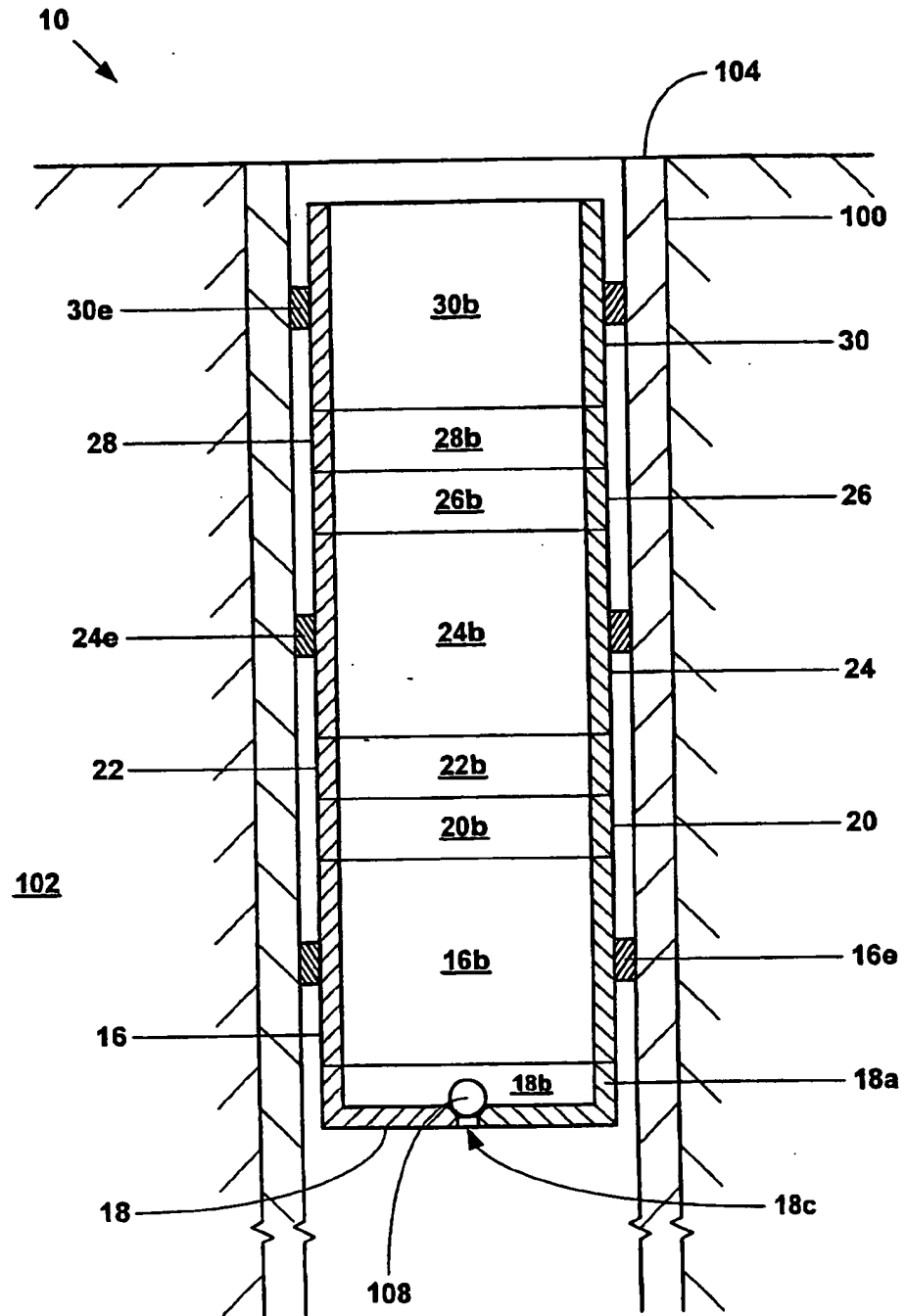

Fig. 1

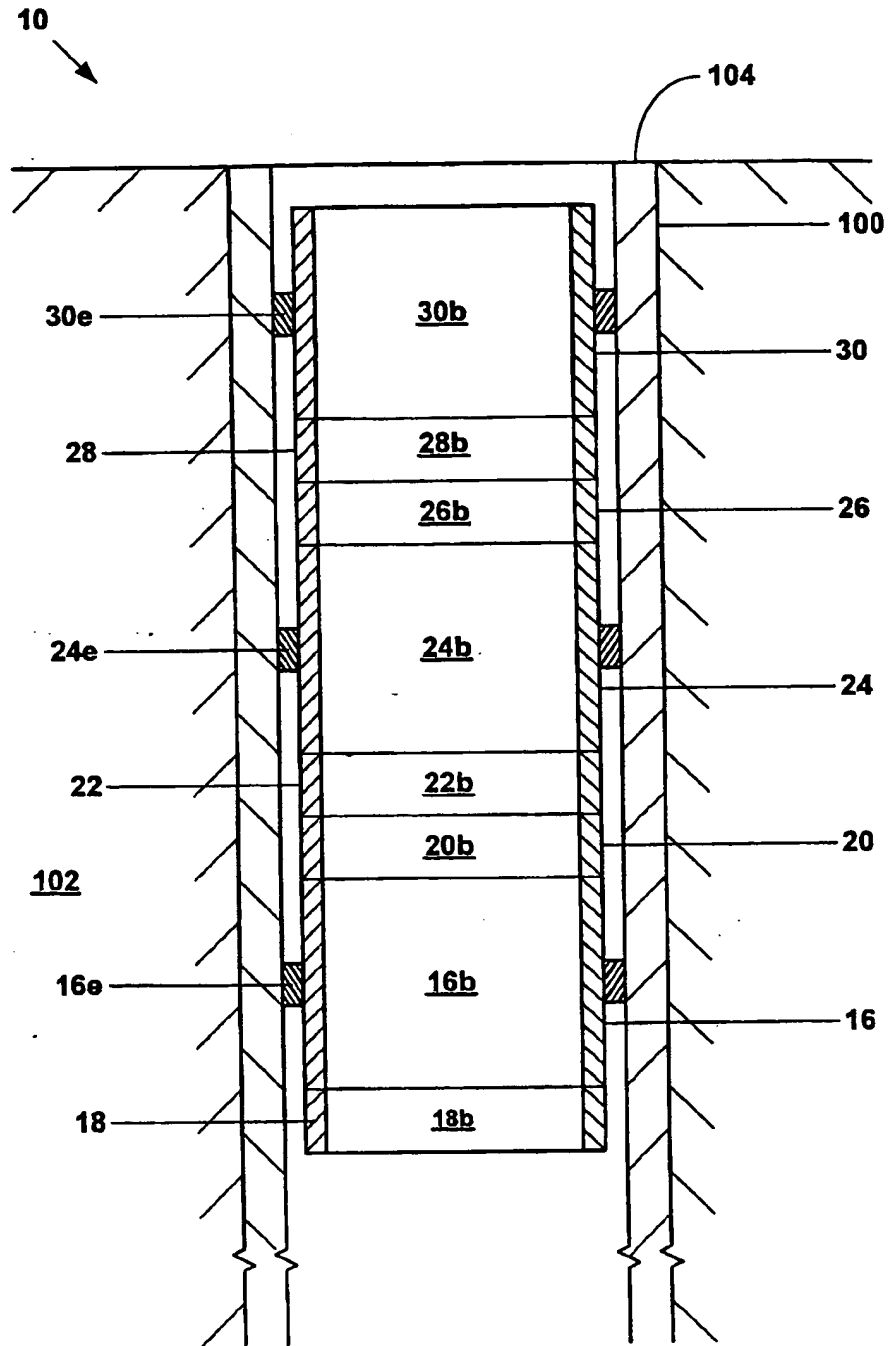

Fig. 1f

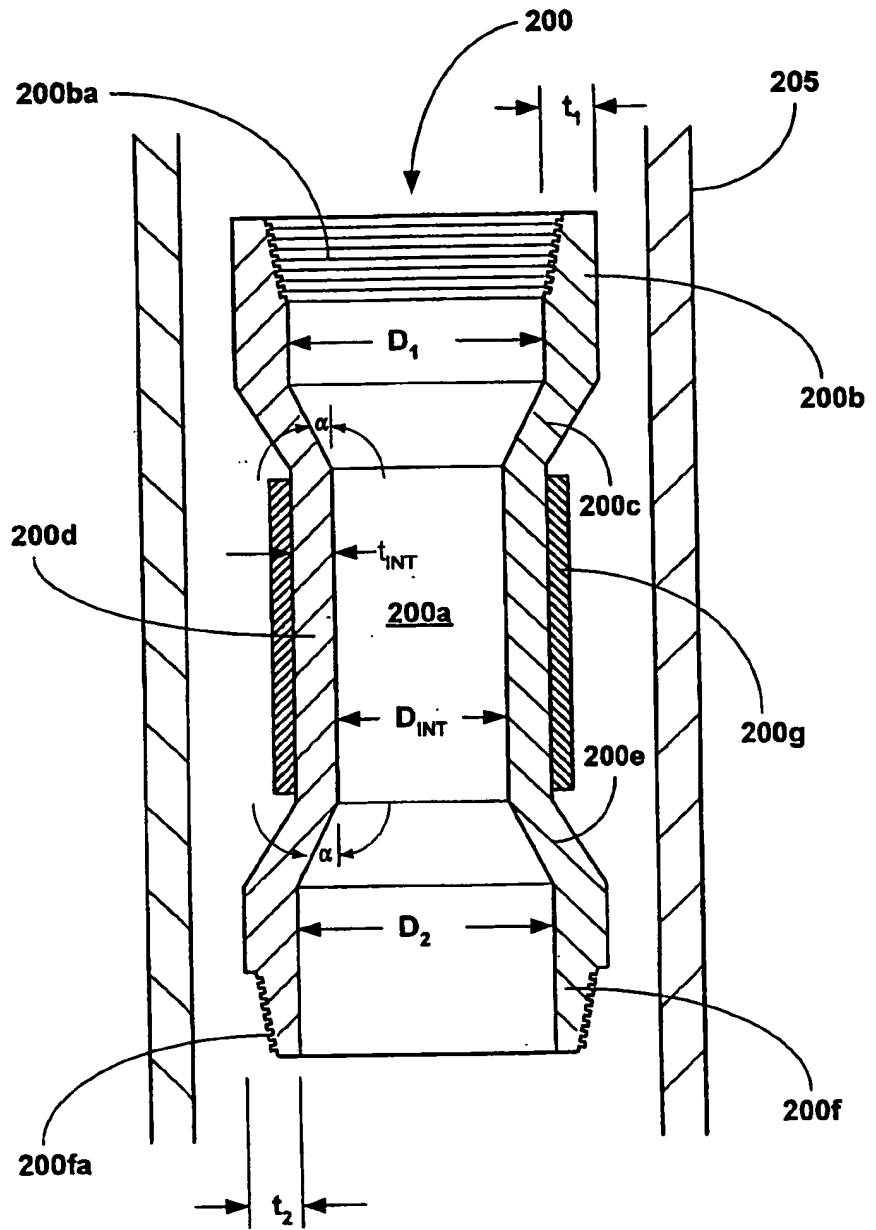

Fig. 2

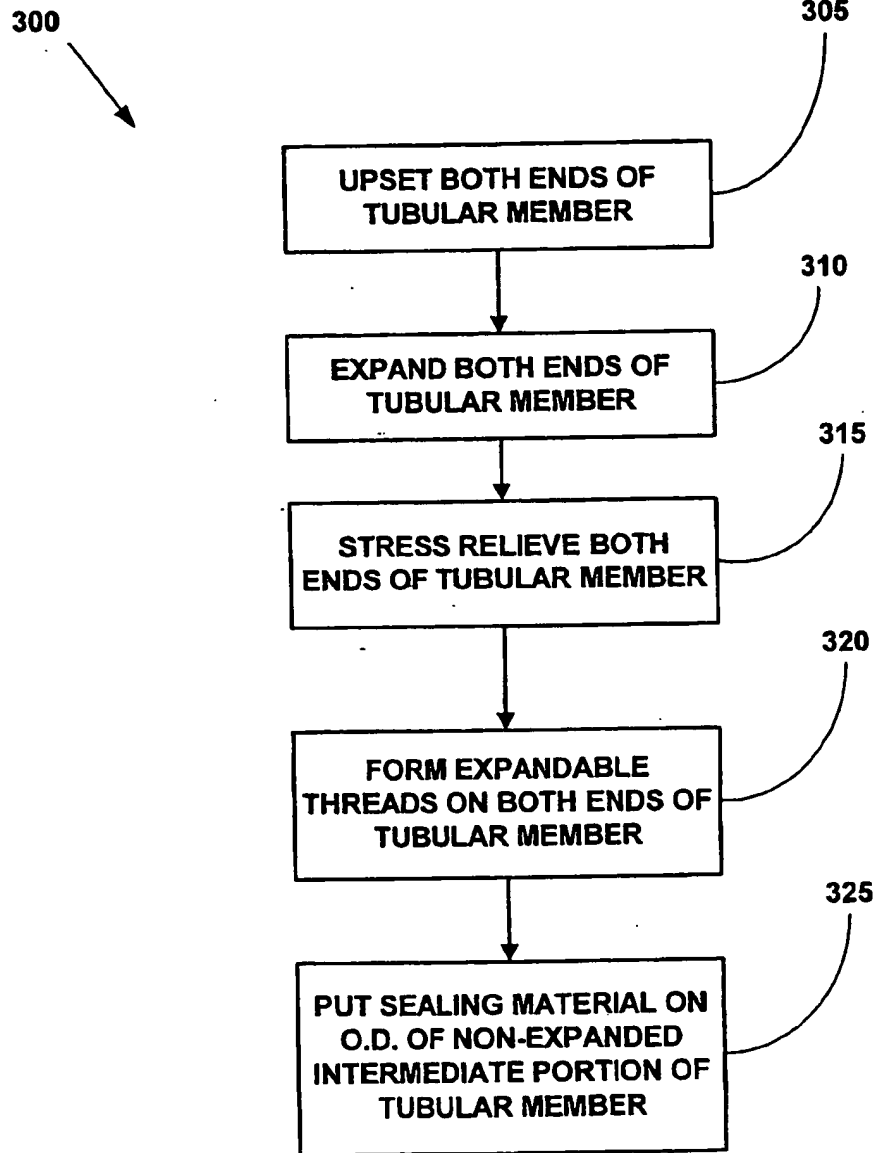
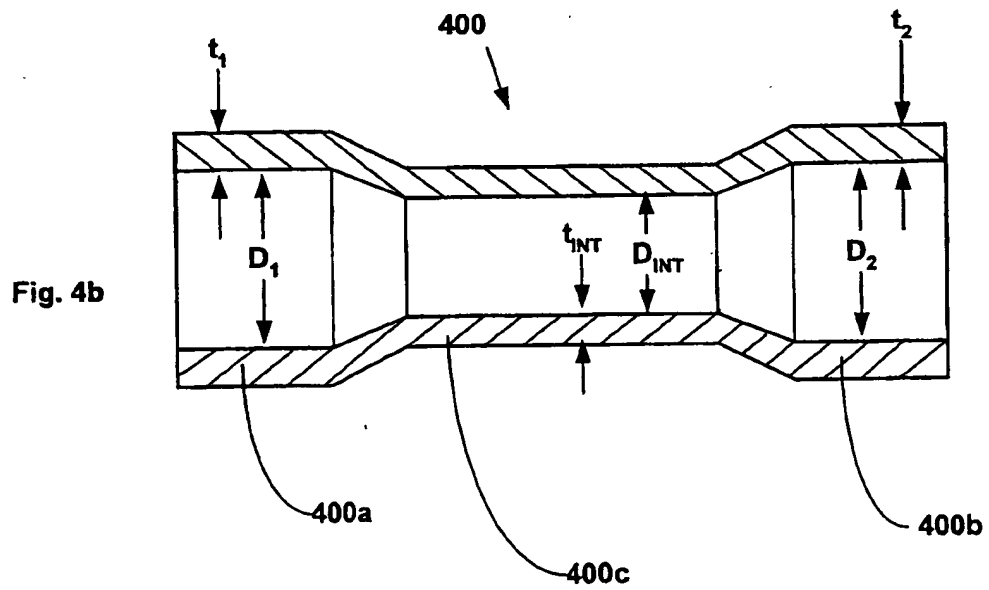
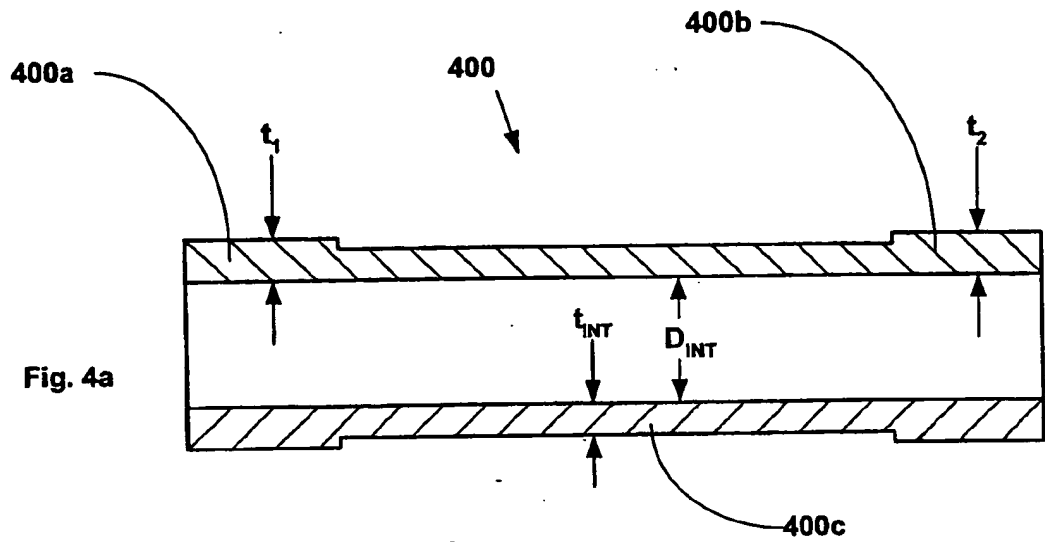

Fig. 3



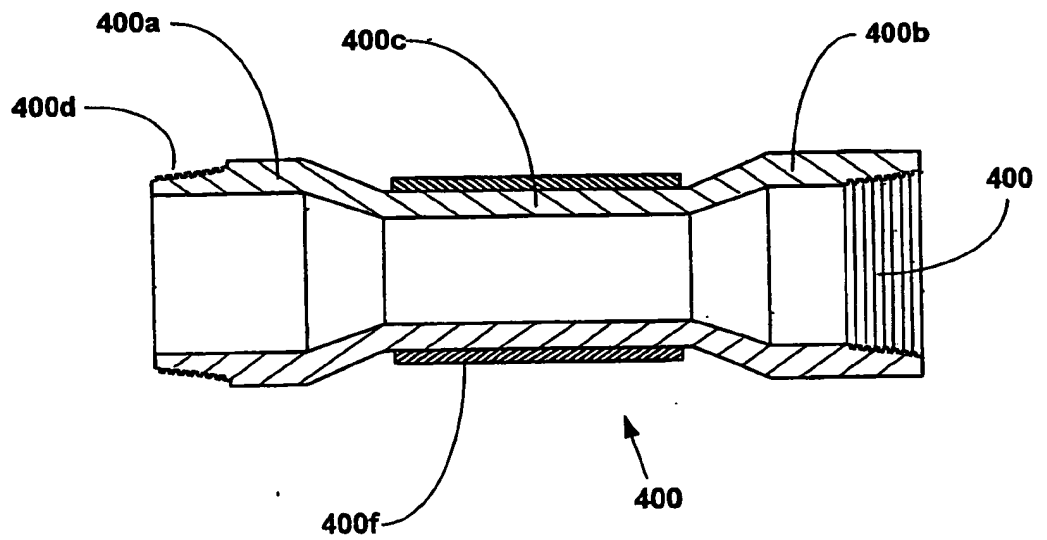
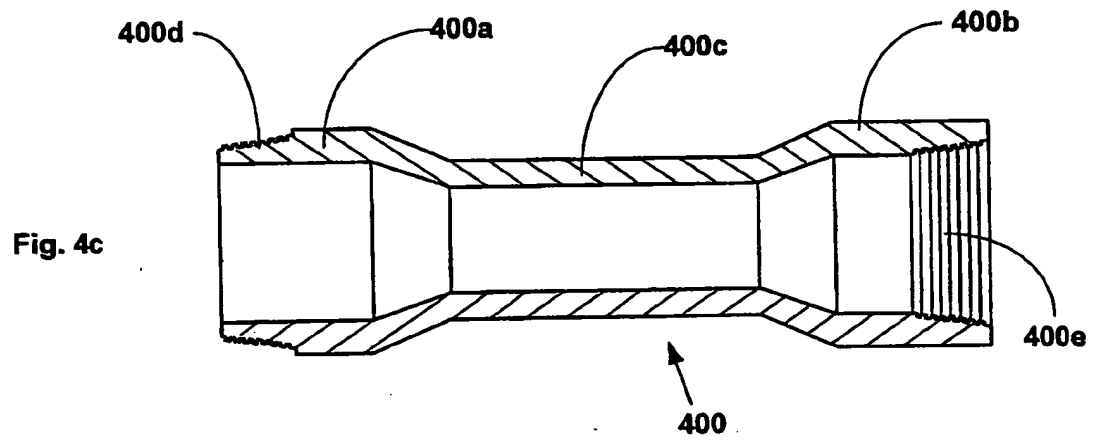

Fig. 4d

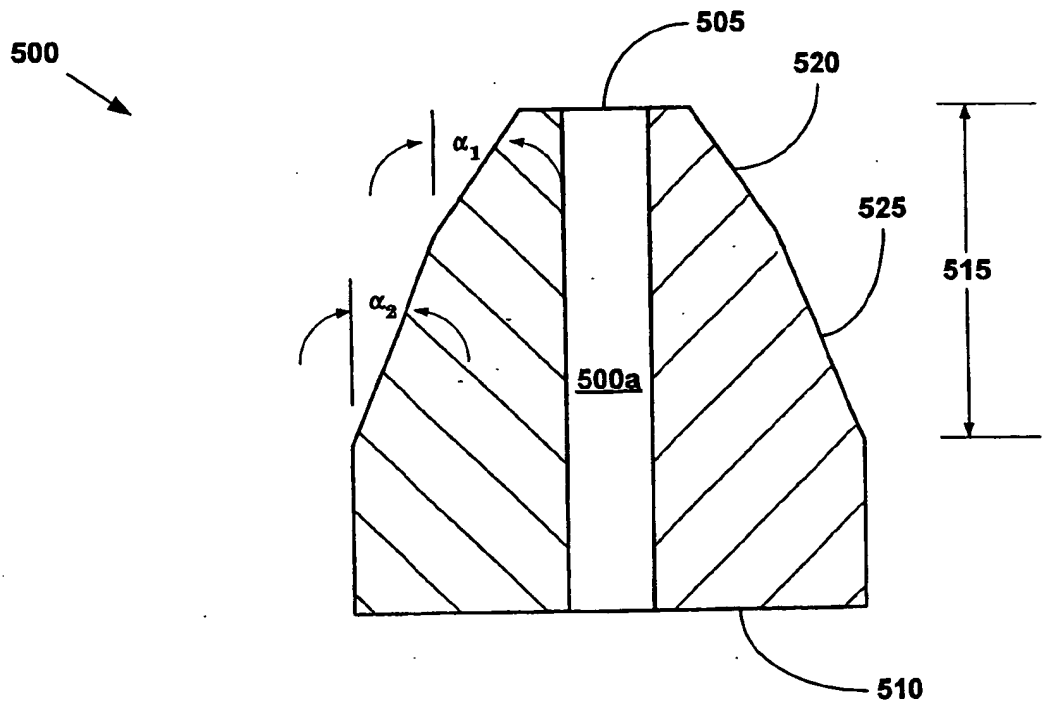

Fig. 5

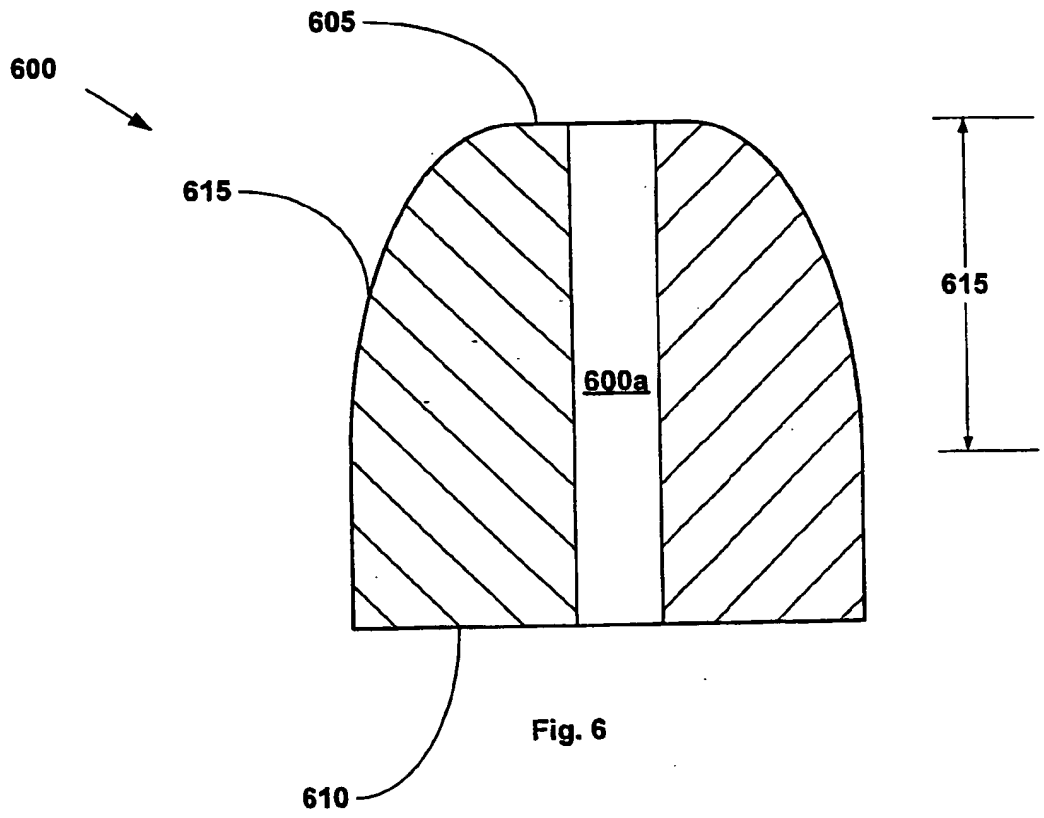

Fig. 6